

# 10K

## Features

1. A general valve based on the 20K type. Can be used for a range of specifications.
2. Support for special fluids by exchanging the packing, gasket and main parts. Please consult with us separately. – We also undertake maintenance using genuine parts.
3. The main parts are made with 13Cr stainless steel and can be used up to 300°C.

## Product Types

Globe, Gate, Check, Needle, Bellows seal, Ball valves and Strainers

### △Caution:

- A cobalt-base alloy (Co-Cr-W alloy) for the valve seat surface is recommended in case of use in the following conditions.
  1. In case of steam piping with a nominal diameter of 150A (6B) or higher.
  2. In case of steam piping when the pressure is 0.98 MPa or higher, and the frequency of opening and closing is high.
  3. In case of use with fluids in a dry state.
  4. In case of piping for chemicals where corrosion resistance is required, and the main parts of the valve are 18Cr-8Ni stainless steel

## Fluid • Temperature • Pressure

Unit: MPa

Service temperature limit by fluid (°C)	Steady water flow		Oil, air, steam, pulsating water						LPG		City gas	
	80	120	80	120	183	220	250	300	120	80	120	
Maximum working pressure by product type MPa	Standard, needle valve											
	Bellows		1.37				1.18	0.98				
	Reinforced PTFE disc		1.37			1.18						
Globe	V-port valve			0.98							0.98	
	Gate		1.37			1.18	0.98					
Check	Standard		1.37			1.18	0.98					
	Reinforced PTFE disc		1.37			0.98						
	NBR disc		1.37	1.37								
Ball	For general use		1.37		1.28	0						
	For gas								1.18		0.98	

\*1 Heat-resistant coating is recommended in case the service temperature exceeds 180°C

## Test Pressure

Unit: MPa

Test description	Body pressure resistance		Valve seat leakage	
	Water pressure	Air pressure	Water pressure	Air pressure
Product Type				
Globe, needle, V-port, gate, check, ball valves	2.10		1.54	
Bellows seal valve		1.00		1.00
Ball valve for gas		1.80		1.32

10K

# 10K

Product Code **BM10KF0B** 10K

Ball Valve for General Use Flanged Full bore

Product Name	Material	Remarks
Body	FCD-S	
Ball	SCS13A	
Stem	SUS403	
Seat ring	FT seat	
Handle	FCMB340	Color: Blue / Nominal diameter: 15-100A
Handle boss + pipe	FCMB340+ STPG	Color: Blue / Nominal diameter: 125-200A
Gasket	Reinforced PTFE	
Gland Packing	PTFE	

△ Indicator: Blue  
External stopper/  
Valve stem: widths across flats

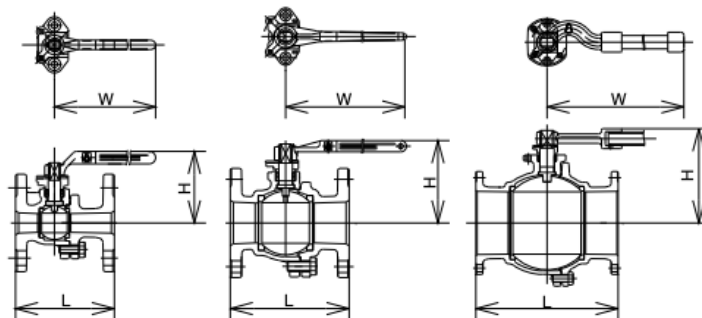

Nominal diameter (A)	15	20	25	32	40	50	65	80	100	125	150	200
L	108	117	127	140	165	178	190	203	229	292	394	457
H	73	76	92	98	110	117	132	170	186	225	245	301
W	120	120	150	150	220	220	220	320	400	800	1000	1200