

# Disc check valve

Model 172

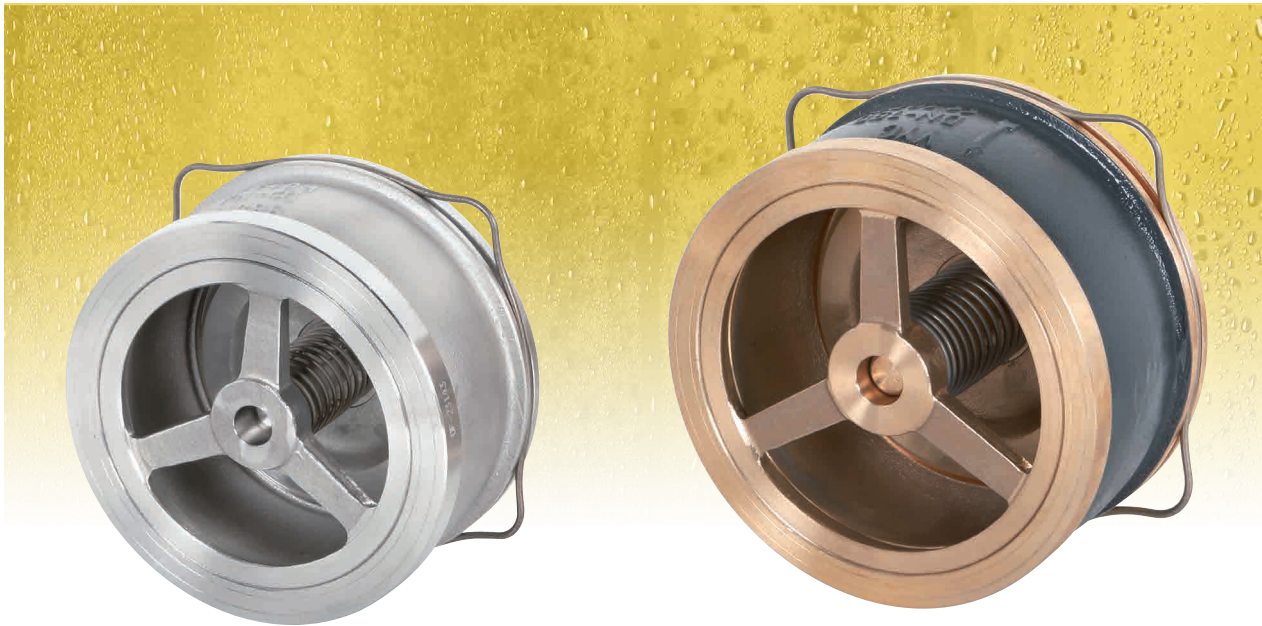

EN ASME/ANSI



Disc check valve with centering ring for placing between flanges in accordance with DIN, UNE, ANSI, BS, etc. norms. DN-125 to 300 (DN-15 to 100 see catalogue for Model 170).

For liquids, gases and steam.

For use in hydraulic, pneumatic, heating and steam systems, chemical and food industries, etc.

In accordance with the requirements of directive 2014/68/EU.

EC valve verification certified by: TÜV Internacional Grupo TÜV Rheinland, S.L. EC 0035.

Final product verification EC examination (Module D) certified by: TÜV Internacional Grupo TÜV Rheinland, S.L.

## Specifications

- Reduced assembly time in accordance with EN-558, basic series 49.
- Minimum load loss.
- Avoids ram shock when closing at zero pressure, remaining completely tightness at the time of fluid reversion.
- Highly watertight, exceeding the requirements of EN 12266-1.
- Easily assembled in any position in accordance with the direction of the fluid flow. Without spring only in vertical ascending direction.
- The valves have one single centering ring for placing between flanges according to DIN and UNE norms (PN-6, 10, 16, 25 and 40), ASA (ANSI) (PSI-150 and 300) and other norms (NF, BS, etc.).

## IMPORTANT

Depending on demand:

- Possibility of manufacture in other types of material, for use in special working conditions (high temperatures, fluids, etc.).

Nº. PIECE	PIECE	MATERIAL															
		CAST IRON				BRONZE				CAST STEEL				STAINLESS STEEL			
1	Body	Cast iron (EN-5.1301)				Bronze (DIN-2.1086.01)				Cast steel (EN-1.0619)				Stainless steel (EN-1.4408)			
2	Seating	Cast iron (EN-5.1301)				Bronze (DIN-2.1086.01)				Stainless steel (EN-1.4401)				Stainless steel (EN-1.4408)			
3	Sealing disc	Nodular iron (EN-5.3106)				Bronze (DIN-2.1086.01)				Stainless steel (EN-1.4408) (2)				Stainless steel (EN-1.4408)			
4	Lead	Nodular iron (EN-5.3106)				Bronze (DIN-2.1086.01)				Stainless steel (EN-1.4408) (3)				Stainless steel (EN-1.4408)			
5	Spring	Stainless steel (EN-1.4571)				Stainless steel (EN-1.4571)				Stainless steel (EN-1.4571)				Stainless steel (EN-1.4571)			
6	Centering ring	Stainless steel (EN-1.4310)				Stainless steel (EN-1.4310)				Stainless steel (EN-1.4310)				Stainless steel (EN-1.4310)			
DN		125 to 300															
PN		16				16				40				40			
OPERATING CONDITIONS	PRESSURE IN bar	16	13	13	13	16	15	14	13	40	35	28	21	40	34	32	29
	MAXIMUM TEMP. IN °C	120	200	250	300	120	180	200	250	120	200	300	400 <sup>(1)</sup>	120	200	300	400 <sup>(1)</sup>
	MINIMUM TEMP. IN °C	-60				-60				-10				-60			

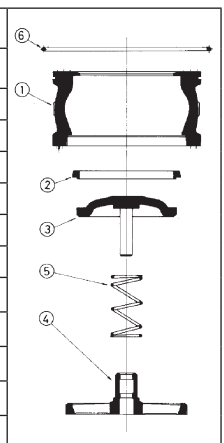

(1) For temperatures exceeding 300°C without spring only or depending on demand, with special spring.

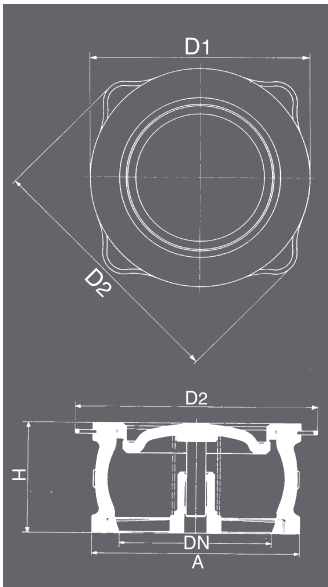

DN		125	150,00	200,00	250,00	300,00
H		90	106,00	140,00	140,00	181,00
A		180	205,00	262,00	315,00	368,00
D		180	205,00	262,00	315,00	368,00
D		205,00	240,00	300,00	412,50	456,50
WEIGHT IN Kgs.	CAST IRON	6,84	9,90	19,57	28,05	42,65
	BRONZE	8,13	12,05	21,66	33,98	53,23
	CAST STEEL	6,90	10,78	19,13	30,28	47,44
	STAINLESS STEEL	6,93	10,83	19,21	30,96	48,49
CODE 2003-172.	CAST IRON	5506	5606	5806	5006	5016
	BRONZE	5501	5601	5801	5001	5011
	CAST STEEL	8504	8604	8804	8004	8014
	STAINLESS STEEL	8502	8602	8802	8002	8012

DIRECTION OF FLUID FLOW	OPENING PRESSURE IN mbar												FLOW COEFFICIENT		
	WITHOUT SPRING			WITH SPRING									Kv m³/h ΔP= 1 bar	Cv l/min ΔP= 1 Psi =0,07 bar	
	CAST IRON	BRONZE	C. STEEL S. STEEL	CAST IRON	BRONZE	C. STEEL S. STEEL	CAST IRON	BRONZE	C. STEEL S. STEEL	CAST IRON	BRONZE	C. STEEL S. STEEL			
▲															
▶															
▼															
▲															
▶															
▼															
DN	125	8,56	11,99	11,43	28,56	29,84	29,27	19,85	19,85	9,29	5,85	6,42	210,00	700,00	
	150	10,39	16,00	14,82	30,39	34,80	33,62	20,80	20,80	8,41	2,80	3,98	349,00	1250,00	
	200	10,24	16,68	16,68	30,24	30,55	30,55	15,86	15,86	3,62	1,34	2,51	640,00	2340,00	
	250	10,62	13,26	12,10	43,62	46,26	45,10	35,00	35,00	22,37	19,73	20,40	1088,00	3917,00	
	300	11,61	14,52	13,23	43,67	46,58	45,28	34,05	34,00	20,44	17,53	18,82	1850,00	6660,00	

### Load losses

The adjoining diagram reflects the load loss curves for water at 20°C. Values are based on valves without springs and installed horizontally. In the case of vertical flow, the variations are virtually unimportant. In order to determine other fluids load losses, calculate the flow of these equivalent to water.

$$QA = \sqrt{\frac{Q}{1.000}} \cdot Q$$

QA = Flow equivalent to water in m3/h.

Q = Fluid density in operating conditions in Kg/m3.

QA = Fluid flow in operating conditions in m3/h.

